



The power behind competitiveness

Delta UPS - Modulon Family

DPH Series, Three Phase
15-105 kVA 208Vac
External Battery Cabinet

User Manual

SAVE THIS MANUAL

This manual contains important instructions and warnings that you should follow during the installation, operation, storage and maintenance of this product. Failure to heed these instructions and warnings will void the warranty.

Copyright © 2019 by Delta Electronics Inc. All Rights Reserved. All rights of this User Manual (“Manual”), including but not limited to the contents, information, and figures are solely owned and reserved by Delta Electronics Inc. (“Delta”). The Manual can only be applied to the operation or the use of this product. Any disposition, duplication, dissemination, reproduction, modification, translation, extraction, or usage of this Manual in whole or in part is prohibited without the prior written permission of Delta. Given that Delta will continuously improve and develop the product, changes may be made to the information in this Manual at any time without obligation to notify any person of such revision or changes. Delta will make all possible efforts to secure the accuracy and the integrity of this Manual. Delta disclaims any kinds or forms of warranty, guarantee, or undertaking, either expressly or implicitly, including but not limited to the completeness, faultlessness, accuracy, non-infringement, merchantability or fitness for a particular purpose of the Manual.

Table of Contents

1. Product Introduction	3
2. Important Safety Instructions.....	4
3. Delta Battery Module (Optional).....	6
3.1 Package Inspection	6
3.2 Wiring Diagram of the Delta Battery Module without Batteries (Optional).....	8
4. Installation and Wiring	9
4.1 Before Installation and Wiring	9
4.2 Installation Environment	10
4.3 Battery Cabinet Transportation.....	11
4.4 Fixing the Battery Cabinet	13
4.5 Pre-wiring Warnings	15
4.6 Installation Procedures	18
4.7 Function Contact	25
5. Technical Specifications	27
Appendix: Warranty	29

1. Product Introduction

The Delta External Battery Cabinet is applicable to DPH-60K-LV and DPH-105K-LV UPS and should be used with the Delta Battery Module (optional).

When the UPS is operating, during a power outage, the battery modules will provide DC power to maintain the UPS operation to supply power to the critical loads.

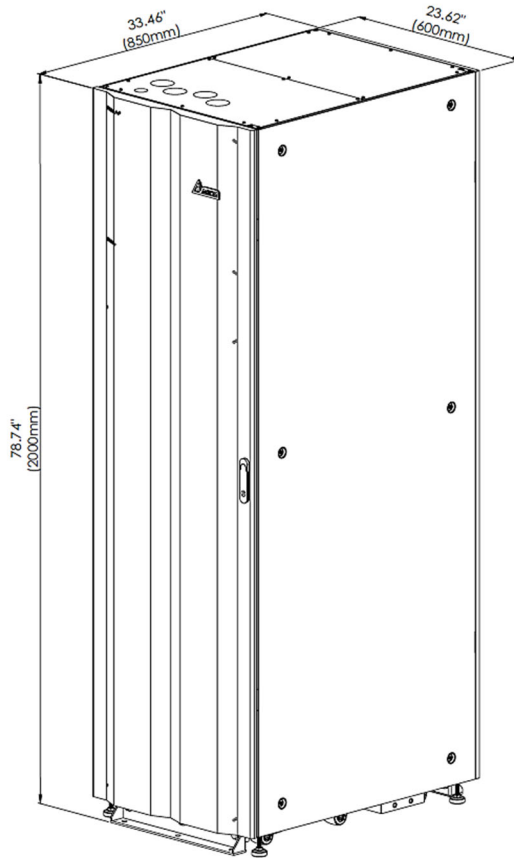

Figure 1: Delta external battery cabinet_ front view

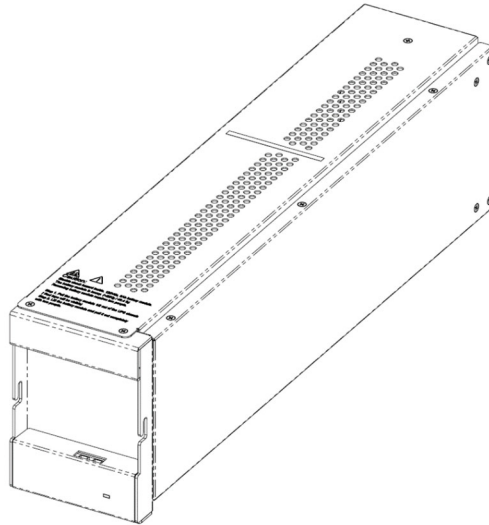

Figure 2: Delta battery module_ front view

2. Important Safety Instructions

- Servicing of batteries, battery modules and battery cabinet must be performed or supervised by qualified service personnel knowledgeable in batteries, battery modules and the battery cabinet as well as their required precautions. Keep unauthorized personnel away from batteries, battery modules and the battery cabinet.
- A battery can present a risk of electric shock and high short-circuit current.
- To reduce the risk of fire or electric shock, install the battery modules in a temperature and humidity controlled indoor area free of conductive contaminants.
- Forbid opening or removing the chassis of both battery modules and Battery Cabinet to avoid high voltage electric shock.
- The risk of dangerous high voltage is possible when the Battery Cabinet still connect to the UPS even though the UPS is disconnected from the mains. Do not forget to turn off the inbuilt breaker of Battery Cabinet to completely cut off the battery source.
- Make sure Battery Cabinet disconnect to UPS before performing battery modules replacement.
- Only use the battery modules from Delta. Never use old and new battery modules at the same time.

- The number of batteries/battery modules must meet UPS requirements.
- The AH of Battery Cabinet must meet or larger than UPS requirements. It is determined by the number of battery modules.
- Do not reverse or short circuit the polarity +, -, and N when connecting the batteries because this will destroy the device and constitute a risk of electric shock or fire.
- Use a voltage meter to measure whether the total voltage, after battery modules connection, is around 180Vdc. (V_{+N} or V_{N-})
- The external slits and openings in the battery modules are provided for ventilation. To ensure reliable operation of the battery modules and to protect the Battery Cabinet from overheating, these slits and openings must not be blocked or covered. Do not insert any object into the slits and openings that may hinder ventilation.
- Do not allow liquid or any foreign object to enter the battery modules and Battery Cabinet.
- Do not place beverages or any other liquid-containing vessels on or near both of battery modules and Battery Cabinet.
- Do not dispose of the batteries or battery modules in a fire. The batteries/battery modules may explode.
- Do not open or mutilate the batteries or battery modules. The released electrolyte is harmful to the skin and eyes and may be toxic.
- Observe the following before replacing battery modules:
 - (1) Remove watches, rings, or other metal objects.
 - (2) Use tools with insulated handles.
 - (3) Wear rubber gloves and boots.
 - (4) Do not lay tools or metal parts on the top of batteries.
 - (5) Disconnect charging source prior to connecting or disconnecting batteries' terminals.

3. Delta Battery Module (Optional)

No.	Item	Function
1	Delta Battery Module (with batteries)	To be installed in the Delta external battery cabinet.
2	Delta Battery Module (without batteries)	<ol style="list-style-type: none"> Provides the space for batteries to be installed. For details, please refer to 3.2 Wiring Diagram of the Delta Battery Module without Batteries (Optional). For how many batteries and what types of batteries that should be installed inside the empty battery module, please contact Delta service personnel for more information. To be installed in the external battery cabinet.

3.1 Package Inspection

- Delta Battery Module (with batteries)

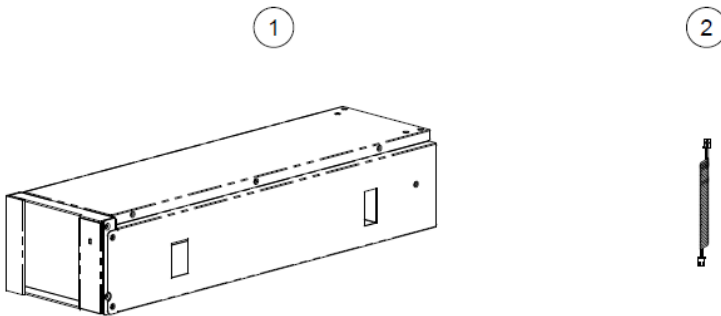

No.	Item	Q'ty
1	Battery Module	1
2	Battery Fuse Detection Wire	1

● **Delta Battery Module (without batteries)**

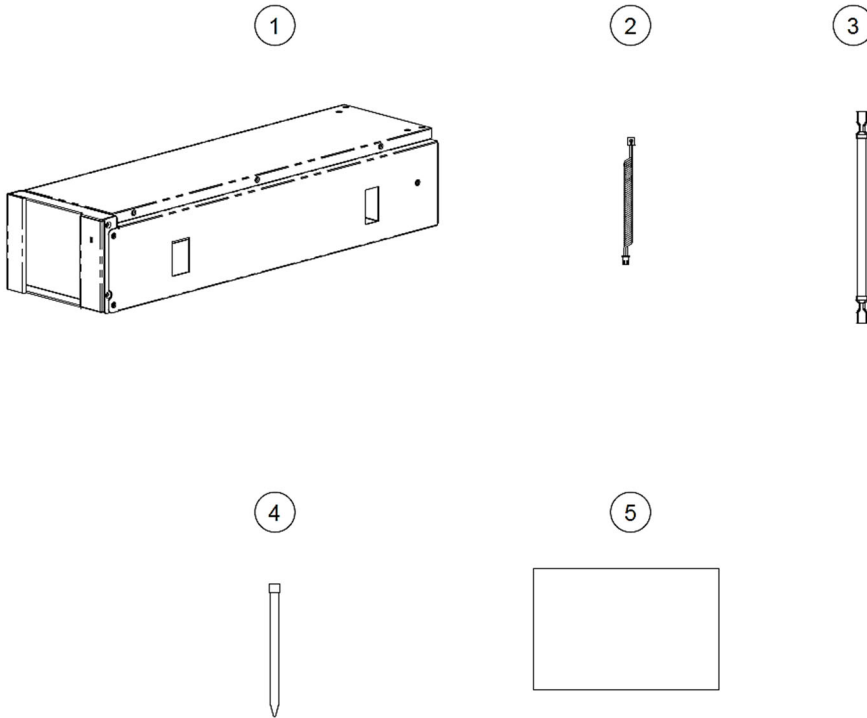

No.	Item	Q'ty
1	Battery Module	1
2	Battery Fuse Detection Wire	1
3	Battery Interconnection Cable	6
4	Cable Tie	2
5	Operation Manual	1

3.2 Wiring Diagram of the Delta Battery Module without Batteries (Optional)

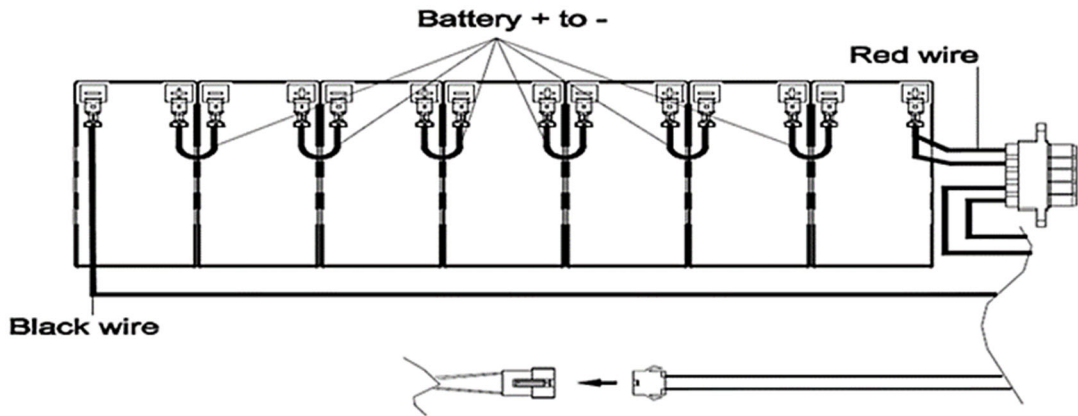

(Figure 3: Delta battery module without batteries (optional)_ battery interconnection)

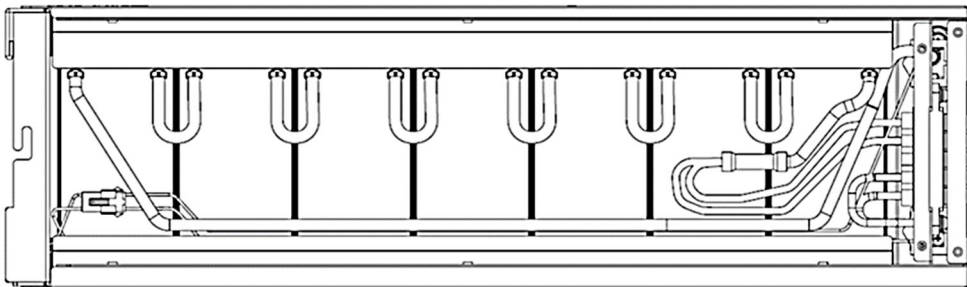

(Figure 4: Delta battery module without batteries (optional)_ internal wiring diagram)

For installation details, please refer to the **Operation Manual** included in the battery module's package.

4. Installation and Wiring

4.1 Before Installation and Wiring

- Please read this user manual thoroughly before installation, wiring and usage. Only authorized Delta engineers or service personnel can perform installation, wiring, panel & cover removal, maintenance and operation. If you want to execute any action mentioned above by yourself, the action must be under the supervision of authorized Delta engineers or service personnel. If you use a forklift or other equipment to move the Battery Cabinet, please make sure its load bearing is sufficient.
- For the configuration of the external battery cabinet, please refer to **Figure 5**. The maximum number of the battery strings is 8.

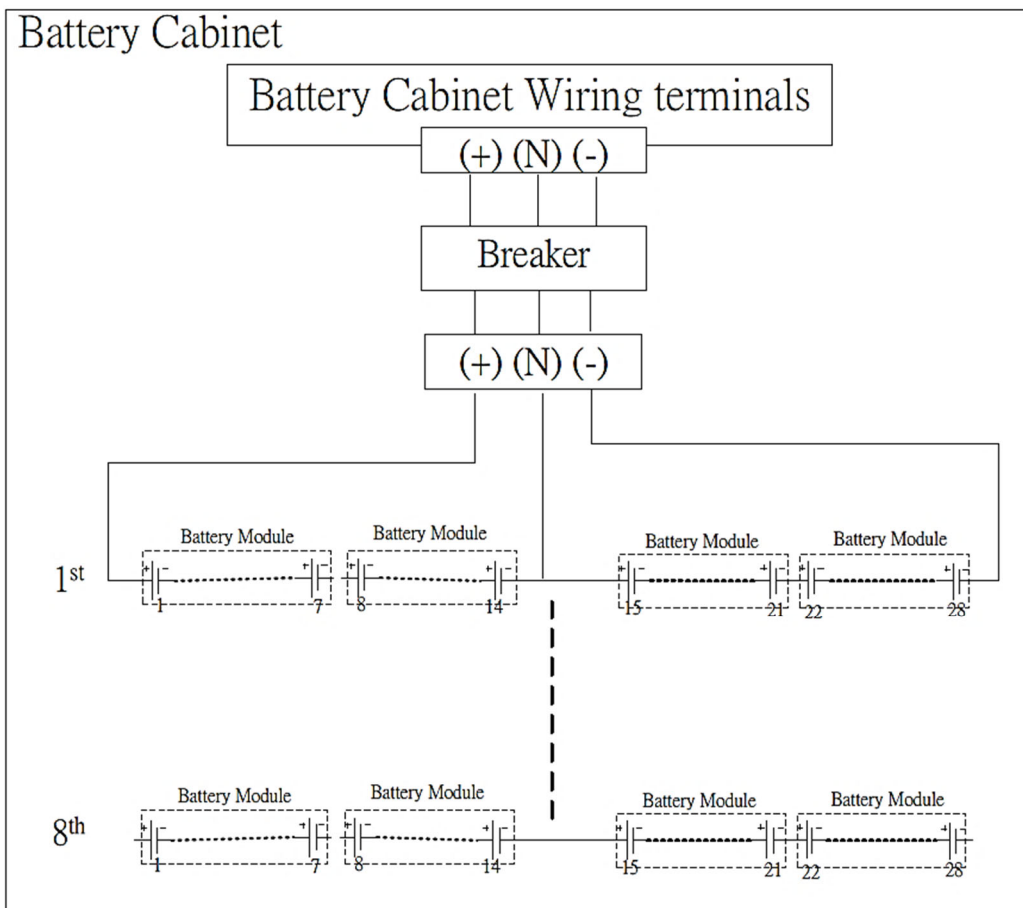

(Figure 5: configuration of the external battery cabinet)

4.2 Installation Environment

- Install the Battery Cabinet indoors. Do not place it outdoors.
- Make sure that transportation routes (e.g. corridors, door gates, elevators, etc.) and installation area can accommodate and bear the weight of the Battery Cabinet, UPS and handling equipment. Please refer to **Table 1** for floor weight loading information.

Table 1: battery cabinet weight loading table

DPH-LV-B								
Battery Cabinet Capacity	9Ah	18Ah	27Ah	36Ah	45Ah	54Ah	63Ah	72Ah
Battery Module Q'ty	4	8	12	16	20	24	28	32
Weight	672.4 lb (305 kg)	879.6 lb (399 kg)	1086.9 lb (493 kg)	1294.1 lb (587 kg)	1501.3 lb (681 kg)	1708.6 lb (775 kg)	1915.8 lb (869 kg)	2123.1 lb (963 kg)
Weight Loading	122.5 lb/ft ² (598 kg/m ²)	160.2 lb/ft ² (782.4 kg/m ²)	198.0 lb/ft ² (966.7 kg/m ²)	235.7 lb/ft ² (1151 kg/m ²)	273.5 lb/ft ² (1335.3 kg/m ²)	311.2 lb/ft ² (1519.6 kg/m ²)	349.0 lb/ft ² (1703.9 kg/m ²)	386.7 lb/ft ² (1888.2 kg/m ²)

- Ensure that the installation area is big enough for maintenance and ventilation. Since the Battery Cabinet adopts the design of air inlet at the front and air outlet at the rear, we suggest that you keep a distance of 17.72" (45 cm) from the top of the Battery Cabinet for wiring, maintenance and ventilation.
- Keep the installation area clean. Please note that wiring routes must be hermetic to prevent possible damage from rodents
- Keep the installation area's temperature around 77°F (25°C) and humidity below 95%. The highest operating altitude is 3300 ft (1000 m) above sea level.

- For safety concerns, we suggest that you:
 - (1) Equip surroundings of the installation area with CO₂ or dry powder fire extinguishers.
 - (2) Install the Battery Cabinet in an environment where fireproof materials are used to construct the walls, floors and ceilings.
 - (3) Install the Battery Cabinet on a floor that is made of noncombustible materials.
- Do not allow unauthorized personnel to enter the installation area and assign specified personnel to keep the Battery Cabinet key.

4.3 Battery Cabinet Transportation

- At the bottom of the Battery Cabinet, there are casters to help you to move the Battery Cabinet to a designated area. Before you move the Battery Cabinet, please turn the four leveling feet counterclockwise to raise them off the ground. This protects the leveling feet from damage when moving the Battery Cabinet. Please arrange sufficient manpower (at least six people) and equipment (e.g. forklift) to carefully move the Battery Cabinet from its pallet to ground. Please pay attention to the movement of the casters to avoid accidents.

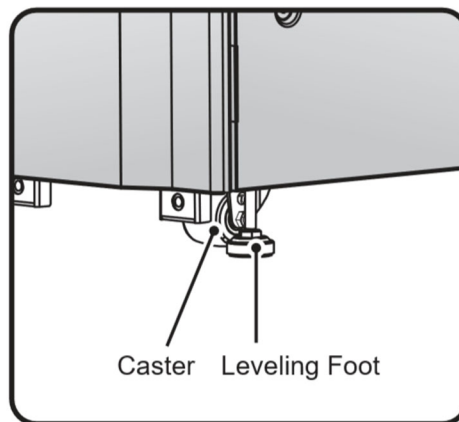

Figure 6: battery cabinet leveling foot and caster

NOTE:

1. The Battery Cabinet is fixed on the pallet with two balance supports. When removing them, pay attention to the movement of the casters to avoid accidents.
2. Please refer to the ***Unpacking Guide*** attached to the Battery Cabinet's external wooden box for the location of the balance supports.

- The casters are designed to move on level ground. Do not move the Battery Cabinet on an uneven surface. This might cause damage to the casters or tip the Battery Cabinet, which could damage the unit.
- After the Battery Cabinet has been removed from the pallet to ground, we suggest that at least three people move the Battery Cabinet to the installation area. With both hands, one person holds a lateral side of the Battery Cabinet, one person holds the other lateral side of the Battery Cabinet with their hands, and one person pushes the Battery Cabinet either from the front or from the rear to move the unit to the installation area and avoid tipping the Battery Cabinet.
- If you need to move the Battery Cabinet over a long distance, please use appropriate equipment like a forklift. Do not use the Battery Cabinet casters to move the unit over a long distance.

4.4 Fixing the Battery Cabinet

Please follow the steps below:

- (1) Before fixing the Battery Cabinet in a designated installation area, please double-check whether the area's floor weight loading is sufficient to bear the Battery Cabinet, UPS and handling equipment (i.e. forklift) to avoid accidents. For Battery Cabinet floor weight loading information, please refer to **Table 1**.
- (2) After the Battery Cabinet is moved to the designated installation area, use an 11/16" (17 mm) socket wrench to stabilize the Battery Cabinet's four leveling feet on the floor. Please note that the Battery Cabinet must stand on the floor stably and levelly without any tipping.
- (3) Use an 11/16" (17 mm) socket wrench and three M10 screws (originally used to fix the front balance support on the pallet) to install the front balance support (removed during the unpacking process) at the front of the Battery Cabinet. Use the three expansion screws and nuts (provided by service personnel) to fix the front balance support on the ground to avoid Battery Cabinet movement. Please see **Figure 7**.

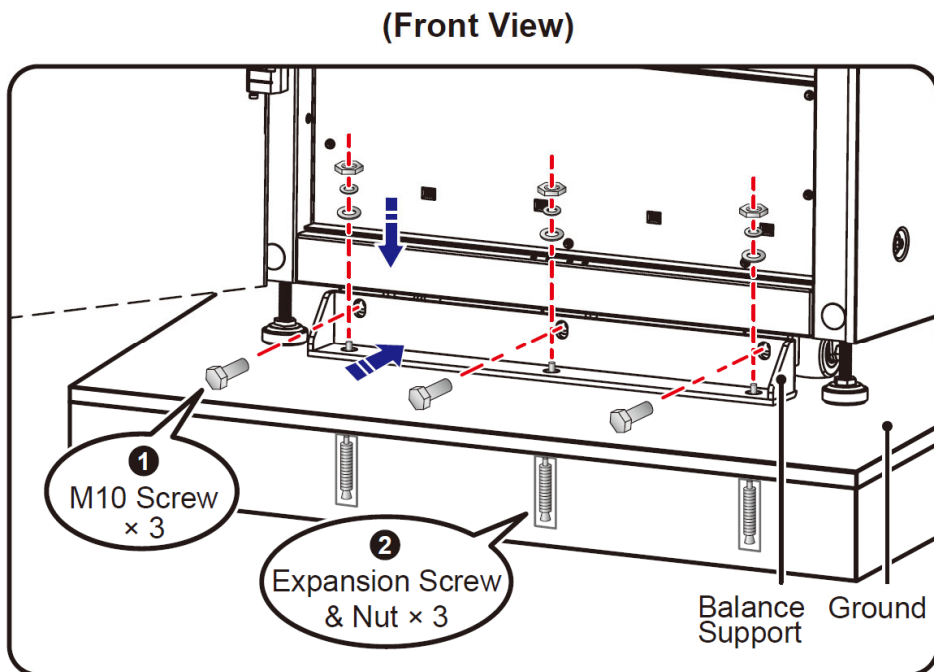

Figure 7: balance support installation_ front of the battery cabinet

- (4) Use an 11/16" (17 mm) socket wrench and three M10 screws (originally used to fix the rear balance support on the pallet) to install the rear balance support (removed during the unpacking process) at the rear of the Battery Cabinet. Use the three expansion screws and nuts (provided by service personnel) to fix the rear balance support on the ground to avoid Battery Cabinet movement. Please see **Figure 8**.

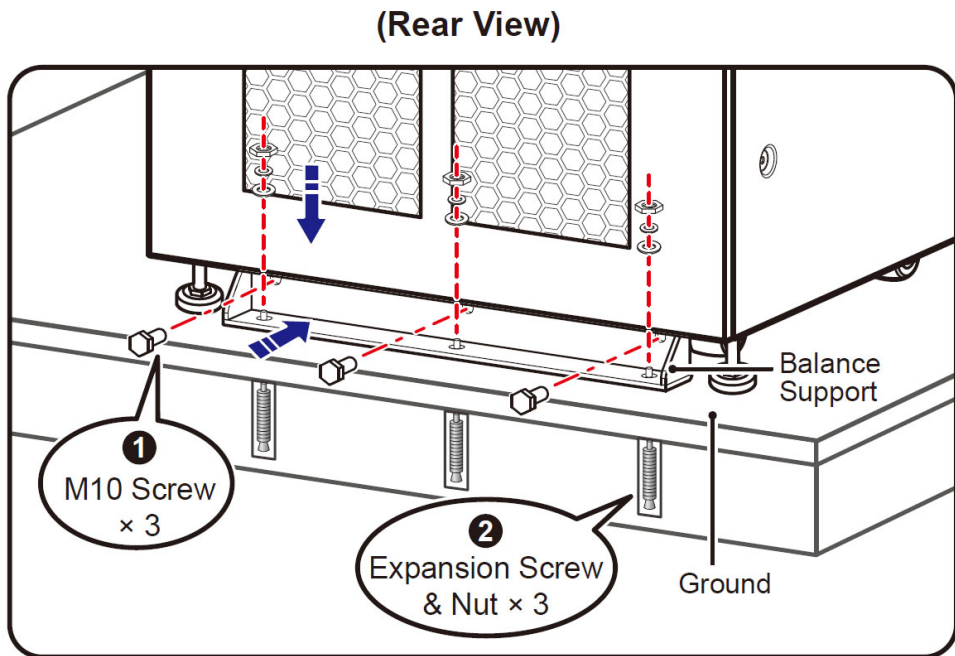

Figure 8: balance support installation _ rear of the battery cabinet

WARNING:

Please stabilize the Battery Cabinet with the two provided balance supports. Otherwise, the Battery Cabinet might topple over.

- (5) Follow **4.6 Installation Procedures** to install the battery modules.
- (6) Follow **4.7 Function Contact** to perform wiring procedures for connection to the UPS.
- (7) After finishing the procedures above, close the Battery Cabinet's front door.

4.5 Pre-wiring Warnings

NOTE:

1. Before wiring, please ensure that you have followed **4.4 Fixing the Battery Cabinet** to fix the Battery Cabinet in the designated installation area firmly.
2. Before wiring, please read **4.6 Installation Procedures** thoroughly.
3. Only authorized Delta engineers or service personnel can perform installation, wiring, panel & cover removal, maintenance and operation. If you want to execute any action mentioned above by yourself, the action must be under the supervision of authorized Delta engineers or service personnel.
4. For battery modules installation, please refer to **4.6 Installation Procedures**.

- Before wiring or making any electrical connection, make sure that the power supplied to the input and output of the UPS is completely cut off. Also, make sure that the inbuilt breaker of the Battery Cabinet is turn OFF to completely cut off the battery source.
- The Battery Cabinet adopts top wiring. Please leave adequate space on the top of the Battery Cabinet to allow cable entry.
- Check that the size, diameter, phase, and polarity are correct for each cable that needs connecting to the Battery Cabinet. Please refer to **Table 2**.

Table 2: specifications of the cables

DPH-LV-B								
Battery Cabinet Capacity	9Ah	18Ah	27Ah	36Ah	45Ah	54Ah	63Ah	72Ah
Battery Module Q'ty	4	8	12	16	20	24	28	32
Rated current	42A	83A	124A	165A	206A	248A	289A	330A
Recommended cable size	6 AWG (13 mm ²) x 1 PC	2 AWG (33 mm ²) x 1 PC	2/0 AWG (67 mm ²) x 1 PC	4/0 AWG (107 mm ²) x 1 PC	1/0 AWG (53 mm ²) x 2 PCS	2/0 AWG (67 mm ²) x 2 PCS	3/0 AWG (85 mm ²) x 2 PCS	4/0 AWG (107 mm ²) x 2 PCS
Terminal Type*1	RNB 14-10	RNBS 38-10	RNB 70-10	RNB 100-10	RNB 60-10	RNB 70-10	RNB 80-10	RNB 100-10

WARNING:

1. The maximum recommended length of the battery cables is 33 ft (10 m). If a longer distance is required, you must use larger cables according to the distance.
2. The battery cabinet is scalable. Therefore, it is highly recommended to use the full-size (maximum rating according to the full battery capacity) cables between the UPS and the battery cabinet irrespective of the UPS rating. This is to ensure safety of the battery input at all times.

NOTE:

1. In accordance with National Electrical Codes (NEC), please install a suitable conduit and bushing for cable protection.
2. Please refer to national and local electrical codes for acceptable non-fuse breakers and cable size.
3. Use 194°F (90°C) copper wires.
4. The tightening torque for an M10 screw should be 217 ± 8.7 lbf-in (250 ± 10 kgf-cm).
5. *¹ The suggested manufacturer is ***K.S. TERMINALS INC.*** You may use equivalent terminals provided by other manufacturers.

4.6 Installation Procedures

- (1) Open the Battery Cabinet's front door, and you will see the internal mechanisms including a wiring terminal cover, a breaker, and eight layers of battery modules with covers. Please refer to **Figure 9**.

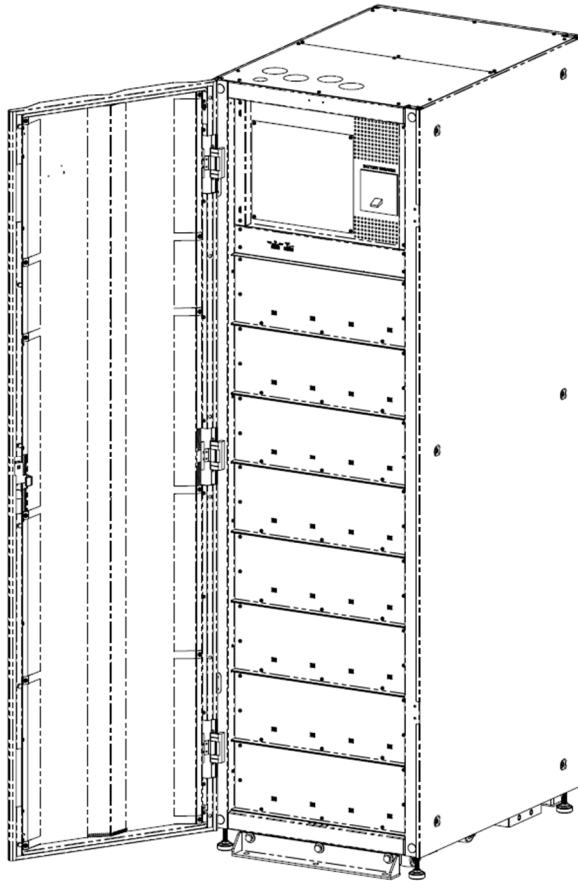

Figure 9: battery cabinet internal view (front view with door open)

- (2) Please remove the wiring terminal cover (see **Figure 10**), and you will see the wiring terminals shown in **Figure 11**.

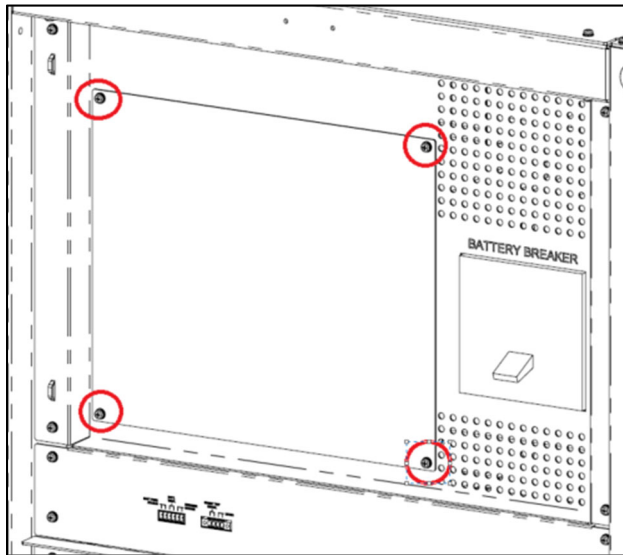

Figure 10: wiring terminal cover_screw location

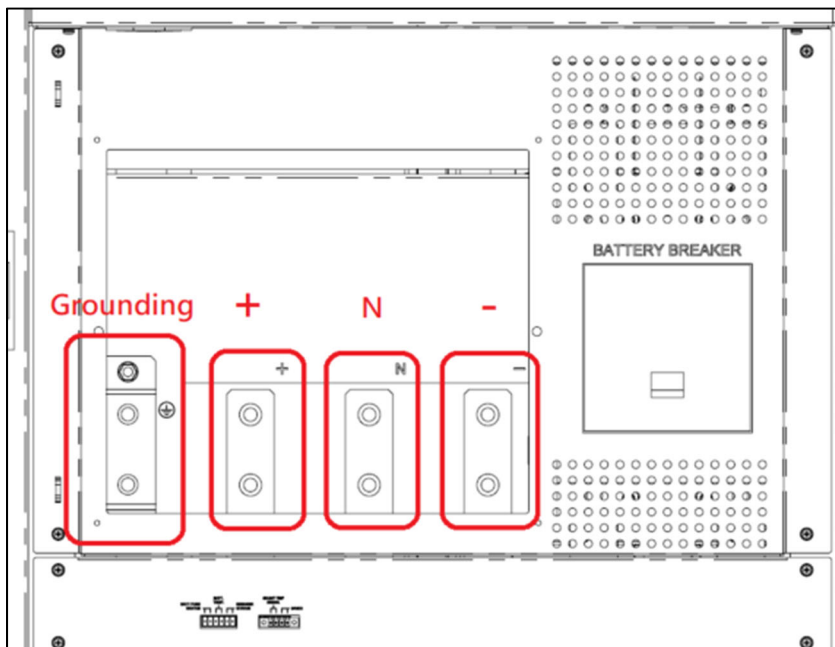

Figure 11: wiring terminals

- (3) For battery module installation, please remove the cover of the battery module. See **Figure 12 ~ Figure 14.**



Figure 12: remove the seven screws

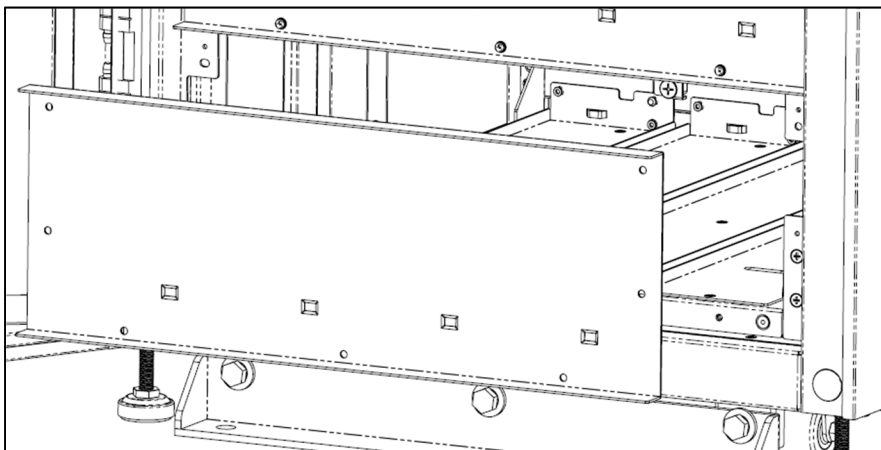

Figure 13: remove the battery cover

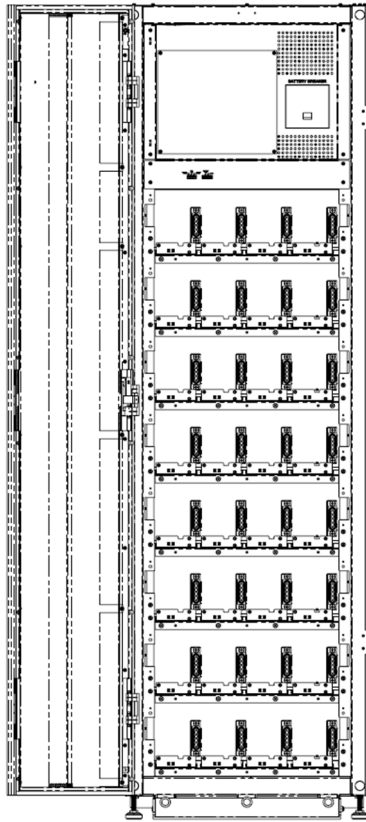

Figure 14: battery cabinet internal view after removing the battery cover

- (4) Insert the battery module into the battery module slot until it snaps into place. Please refer to **Figure 15**.

NOTE:

1. Please pay attention to the cables on the left and right sides, which do not hinder the loading of the battery modules.
2. When inserting the battery modules, please keep the cables from sharp edges to avoid possible cut or damage of the cable insulation.
3. To consider the center of gravity, please install the battery modules from the bottom layer of the battery module slot to the top layer of the battery module slot in sequence.

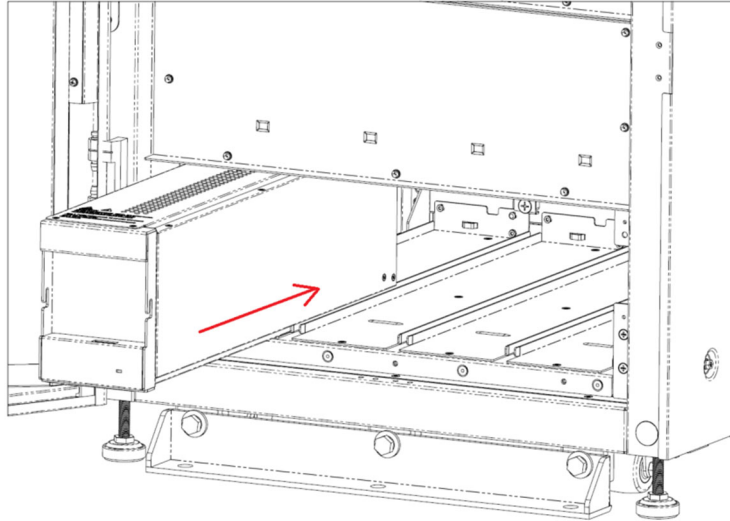

Figure 15: insert the battery module

- (5) Connect the two cables from the sides of the cabinet into the battery modules. See **Figure 16**. Also, connect the three cables from each battery modules into another one. See **Figure 17**.

NOTE:

The three cables in the middle should be placed in the hook groove to avoid extrusion.

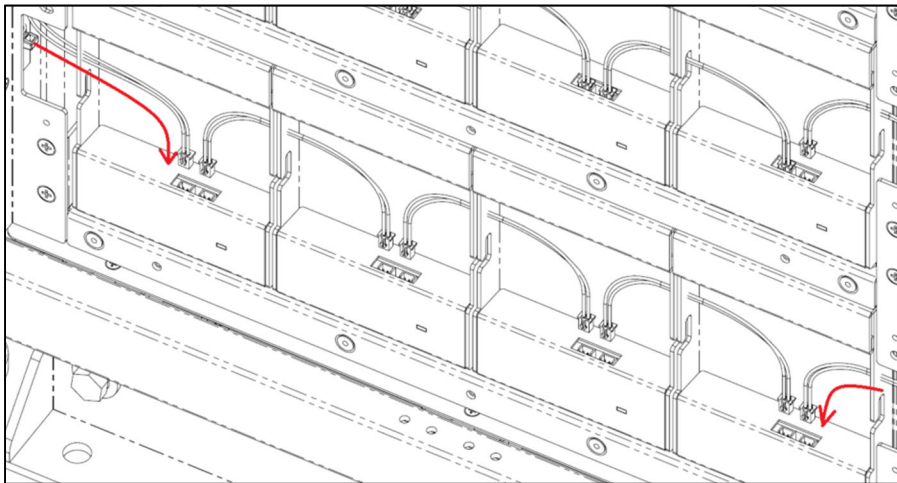

Figure 16: connect the two cables from the sides

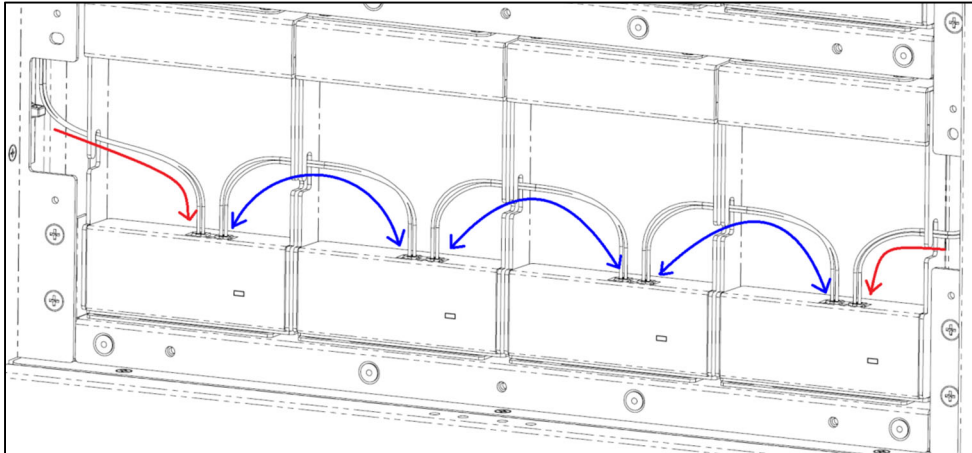

Figure 17: connect the battery modules to each other

- (6) There are eight layers. Four battery modules should be installed in a layer at the same time. See **Figure 18 ~ Figure 19**.

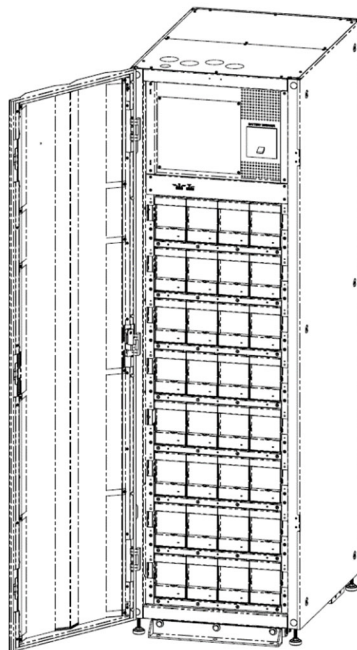

Figure 18: internal view after inserting all battery modules (without cables)

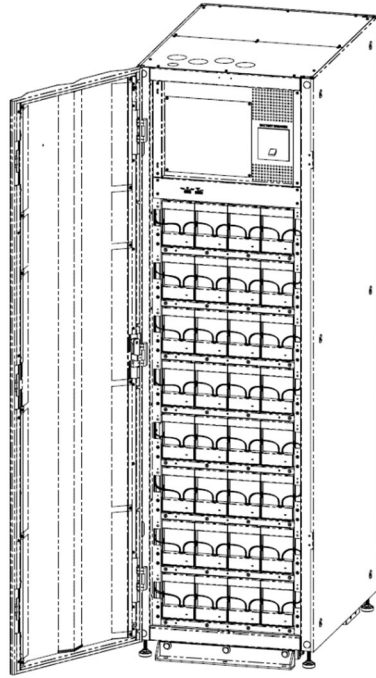

Figure 19: internal view after insert all battery modules (with cables)

- (7) Install the battery cover with seven screws when you finish inserting the battery modules with cables. See **Figure 20**.

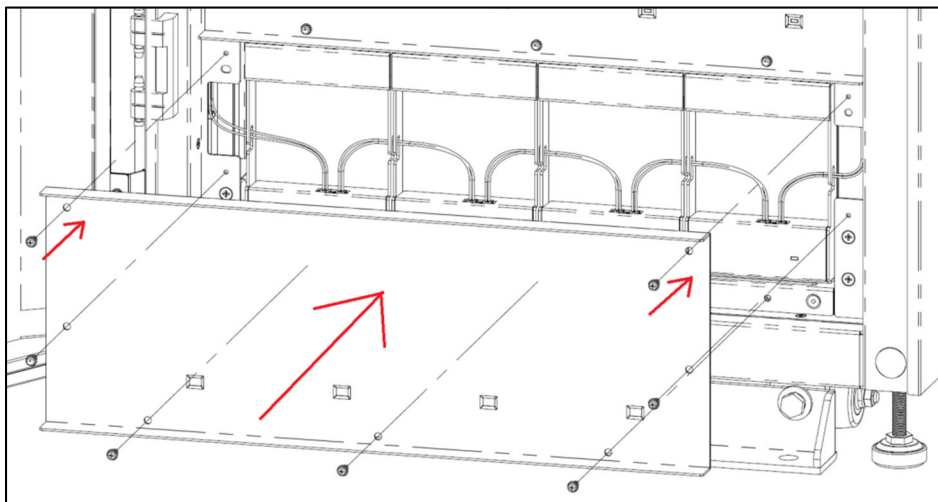

Figure 20: install the battery cover into the cabinet

4.7 Function Contact

- Please refer to **Table 3** and **Figure 21** for the function contact of the Battery Cabinet.

Table 3: function contact of battery cabinet

Item of Function Contact	Description
BATT. FUSE STATUS	Connects to the UPS's input dry contact which is set as ' <i>Battery Fuse Open</i> '.
BATT. TEMP.	Connects to the UPS's ' <i>EXT. BATT. TEMP.</i> ' connector.
BREAKER STATUS	Connects to the UPS's input dry contact which is set as " <i>External Battery Breaker Detection</i> ".
SHUNT TRIP SIGNAL	Connects to the UPS's output dry contact which is set as " <i>Battery Breaker Shunt Trip</i> ".
24VDC	Provides 24Vdc / 120W power supply.

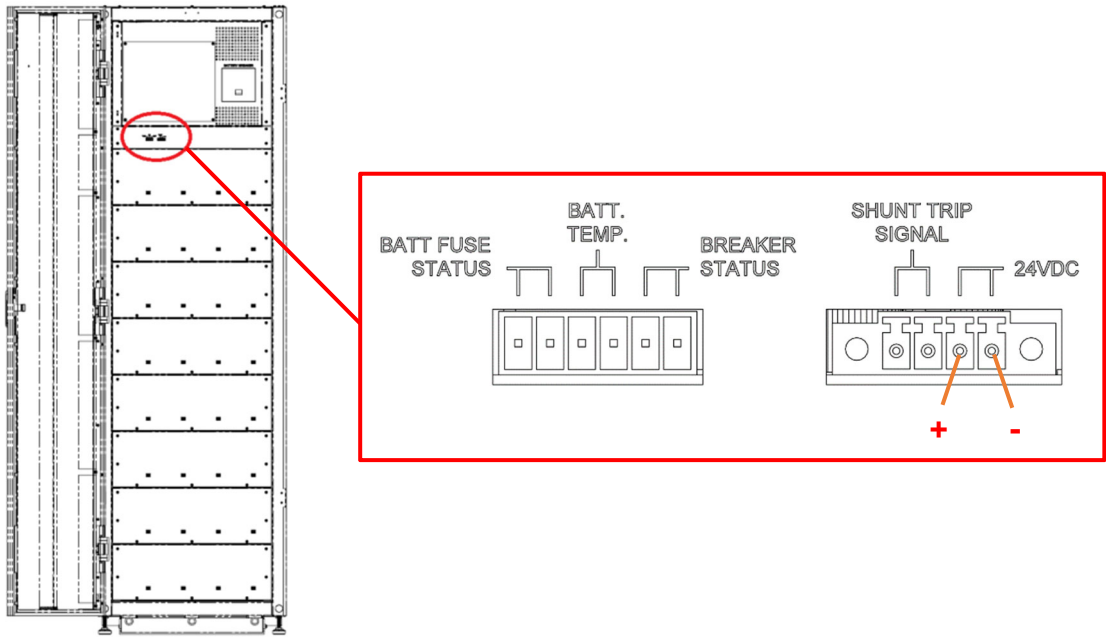

Figure 21: function contact of battery cabinet

WARNING:

1. When the UPS sends the “shunt trip signal” to trip the breaker, it requires 24Vdc/ 120W power to trip the breaker. If the power is below 120W or under 24Vdc, the tripping device may not work. The power must be supplied from an isolated power source.
2. For installation of the power supply device, please contact Delta customer service. Only authorized Delta engineers or service personnel can perform the installation.

NOTE:

1. Suitable cable size of the function contact is 22 ~ 18 AWG.
2. Strip length of the cables should be 0.35” ~ 0.39” (9 ~ 10 mm).
3. The maximum length (recommended) of the cables connected to the UPS is 33 ft (10 m).
4. The maximum length (recommended) of the cables connected to the 24Vdc power supply is 6.6 ft (2 m).

5. Technical Specifications

Delta Battery Cabinet		
Applicable to DPH-60K-LV & DPH-105K-LV UPS		
Battery Voltage		±168Vdc
Maximum Number of Battery Strings		8
Maximum Number of Battery Modules		32
Dimensions (W × D × H)		23.62" × 33.46" × 78.74 " (600 × 850 × 2000 mm)
Weight w/ Full Battery Modules		2123.1 lb (963 kg)
Weight w/o Battery Modules		465.2 lb (211 kg)
Environment	Operating Temperature	32 ~ 104°F (0 ~ 40°C) Recommended: 77°F (25°C)
	Relative Humidity	5% ~ 95% (Non-condensing)

Delta Battery Module

Applicable to DPH-60K-LV & DPH-105K-LV UPS

Battery	Vendor	Hitachi
	Type	UPS12580
	Q'ty	7
Dimensions (W × D × H)		6.09" × 20.81" × 4.35" (154.7 × 528.7 × 110.5 mm)
Weight w/ Full Batteries		51.81 lb (23.5 kg)
Environment	Operating Temperature	32 ~ 104°F (0 ~ 40°C) Recommended: 77°F (25°C)
	Relative Humidity	5% ~ 95% (Non-condensing)

Appendix : Warranty

Seller warrants this product, if used in accordance with all applicable instructions, to be free from original defects in material and workmanship within the warranty period. If the product has any failure problem within the warranty period, Seller will repair or replace the product at its sole discretion according to the failure situation.

This warranty does not apply to normal wear or to damage resulting from improper installation, operation, usage, maintenance or irresistible force (i.e. war, fire, natural disaster, etc.), and this warranty also expressly excludes all incidental and consequential damages.

Maintenance service for a fee is provided for any damage out of the warranty period. If any maintenance is required, please directly contact the supplier or Seller.



WARNING:

The individual user should take care to determine prior to use whether the environment and the load characteristic are suitable, adequate or safe for the installation and the usage of this product. The User Manual must be carefully followed. Seller makes no representation or warranty as to the suitability or fitness of this product for any specific application.

No. : 501327860000

Version : V 0.0

Release Date : 2019_12_12

- Global Headquarter

Taiwan

Delta Electronics Inc.
39 Section 2, Huandong Road, Shanhua District,
Tainan City 74144, Taiwan
T +886 6 505 6565
E ups.taiwan@deltaww.com

- Regional Office

The United States

Delta Electronics (Americas) Ltd.
46101 Fremont Blvd. Fremont, CA 94538
T +1 510 344 2157
E ups.na@deltaww.com

Australia

Delta Energy Systems Australia Pty Ltd.
Unit 20-21, 45 Normanby Road, Notting Hill VIC 3168, Australia
T +61 3 9543 3720
E ups.australia@deltaww.com

South America

Delta Greentech (Brasil) S/A
Rua Itapeva, 26 - 3º andar Edificio Itapeva One - Bela Vista
01332-000 - São Paulo - SP - Brazil
T +55 11 3568 3850
E ups.brazil@deltaww.com

Thailand

Delta Electronics (Thailand) Public Co.,Ltd.
909 Soi 9, Moo 4, E.P.Z., Bangpoo Industrial Estate, Tambon Prakasa,
Amphur Muang-samutprakarn, Samutprakarn Province 10280, Thailand
T +662 709-2800
E ups.thailand@deltaww.com

China

Delta GreenTech (China) Co., Ltd.
238 Minxia Road, Pudong, Shanghai, 201209 P.R.C
T +86 21 5863 5678
+86 21 5863 9595
E ups.china@deltaww.com

South Korea

Delta Electronics (Korea), Inc.
1511, Byucksan Digital Valley 6-cha, Gasan-dong, Geumcheon-gu,
Seoul, Korea, 153-704
T +82-2-515-5303
E ups.south.korea@deltaww.com

Singapore

Delta Electronics Int'l (Singapore) Pte Ltd.
4 Kaki Bukit Ave 1, #05-04, Singapore 417939
T +65 6747 5155
E ups.singapore@deltaww.com

India

Delta Power Solutions (India) Pvt. Ltd.
Plot No. 43, Sector-35, HSIIDC, Gurgaon-122001, Haryana, India
T +91 124 4874 900
E ups.india@deltaww.com

EMEA

Delta Electronics (Netherlands) BV
Zandsteen 15, 2132MZ Hoofddorp, The Netherlands
T +31 20 655 09 00
E ups.netherlands@deltaww.com



5013278600