

The power behind competitiveness

Delta Infrasuite Power Management

Power Distribution Unit

User Manual

www.deltapowersolutions.com



DELTA
Smarter. Greener. Together.

Save This Manual

This manual contains important instructions and warnings that you should follow during the installation, operation, storage and maintenance of this product. Failure to heed these instructions and warnings will void the warranty.



NOTE:

This manual is applicable to the following models: PDU1211B, PDU1313B and PDU2316B.

Copyright © 2019 by Delta Electronics Inc. All Rights Reserved. All rights of this User Manual (“Manual”), including but not limited to the contents, information, and figures are solely owned and reserved by Delta Electronics Inc. (“Delta”). The Manual can only be applied to the operation or the use of this product. Any disposition, duplication, dissemination, reproduction, modification, translation, extraction, or usage of this Manual in whole or in part is prohibited without the prior written permission of Delta. Given that Delta will continuously improve and develop the product, changes may be made to the information in this Manual at any time without obligation to notify any person of such revision or changes. Delta will make all possible efforts to secure the accuracy and the integrity of this Manual. Delta disclaims any kinds or forms of warranty, guarantee, or undertaking, either expressly or implicitly, including but not limited to the completeness, faultlessness, accuracy, non-infringement, merchantability or fitness for a particular purpose of the Manual.

Table of Contents

Chapter 1 : Important Safety Instructions	1
1.1 Safety Precautions	1
1.2 Precautions for Rack Mounting	1
1.3 Precautions for Connecting to a Power Source	2
1.4 Maintenance with Input Power	3
1.5 Electromagnetic Interference	3
Chapter 2 : PDU Overview	4
2.1 Product Introduction	4
2.2 Package Contents	4
Chapter 3 : PDU Installation	5
3.1 Toolless Mounting (Delta Standard Rack Cabinet)	5
3.2 Bracket Mounting (For Other Rack Cabinets)	6
Chapter 4 : PDU Connection	8
4.1 Plug in the PDU	8
4.2 Attaching Cords	8
Chapter 5 : Display Operation	11
5.1 Front Panel Descriptions	11
5.2 Scroll Button	12
5.3 View the Display for Each Circuit	13
5.4 Invert the Numerical Display	13
5.5 Start-up or Reset	13
5.6 Normal Conditions	13
5.7 Alarm Conditions	14

Chapter 6 : Communications -----15

- 6.1 PDU Data-----15
- 6.2 Serial Ports-----15
- 6.3 Communication SNMP module (Optional)-----16

Appendix 1 : Specifications -----17

Appendix 2 : Warranty -----18

Chapter 1 : Important Safety Instructions

1.1 Safety Precautions

To reduce the risk of personal injury from electric shock, you must observe the following safety precautions when placing, installing, operating, or performing maintenance on the Delta Power Distribution Unit (PDU).

- This product is designed for indoor use only in a controlled environment away from excess moisture, temperature extremes, conductive contaminants, dust or direct sunlight.
- Do not connect the PDU to an ungrounded outlet or extension cords or adapters that eliminate the connection to ground.
- Do not use this equipment in the presence of flammable substances.
- The power requirement for each piece of equipment connected to the PDU must not exceed the individual outlet's load rating.
- The total power requirement for equipment connected to the PDU must not exceed the maximum load rating for the PDU.
- Do not drill into or attempt to open any part of the PDU housing. There are no user serviceable parts inside.
- Do not modify the PDU, including the input plugs and power cables.
- Do not use the PDU if any part of it becomes damaged.
- Do not mount the PDU to an insecure or unstable surface.
- Never install electrical equipment during a thunderstorm.

1.2 Precautions for Rack Mounting

- **Elevated Operating Ambient** : If installed in a closed or multi-unit rack assembly, the operating ambient temperature of the rack environment may be greater than room ambient. Therefore, consideration should be given to installing the equipment in an environment compatible with the maximum ambient temperature (T_{ma}) specified by the manufacturer.

- **Reduced Air Flow** : Installation of the equipment in a rack should be such that the amount of air flow required for safe operation of the equipment is not compromised.
- **Mechanical Loading** : Mounting of the equipment in the rack should be such that a hazardous condition is not achieved due to uneven mechanical loading.
- **Circuit Overloading** : Consideration should be given to the connection of the equipment to the supply circuit and the effect that overloading of the circuits might have on over-current protection and supply wiring. Appropriate consideration of equipment nameplate ratings should be used when addressing this concern.
- **Reliable Earthing** : Reliable earthing of rack-mounted equipment should be maintained. Particular attention should be given to supply connections other than direct connections to the branch circuit (such as use of power strips).

1.3 Precautions for Connecting to a Power Source

- Only a certified electrician can connect the PDU with a power source.
- Do not remove the cover. There are no internal components a user can service.
- A certified electrician must install a circuit breaker when connecting the PDU to a power source. This protects the PDU against over-current.
- A certified electrician must determine the type of circuit breaker required depending on the input voltage.
- Before connecting the power supply, make sure you verify the earth connection.
- The use of a detachable input power cord is prohibited.
- The plug on the power supply cord is intended to serve as the disconnect device. The socket-outlet shall be installed near the equipment and shall be easily accessible.
- The short-circuit protection device is considered to be provided external to the equipment, a circuit breaker with adequate breaking (rupturing) capacity to interrupt the maximum fault current is provided between the equipment and the building installation. See below external protective devices for detail.

The external short-circuit/ over-current protective devices (circuit breaker):

- Model PDU1211B: 20A
- Model PDU1313B: 30A
- Model PDU2316B: 60A

1.4 Maintenance with Input Power

Delta strongly recommends that you do not perform maintenance on the PDU if it is receiving input power. However, if critical maintenance is required on the PDU connected to input power, please reduce your risk of electric shock by strictly following the precautions below.

To reduce your risk of personal injury by electric shock, you must:

- Be a certified electrician trained in live electrical installation.
- Always work with another qualified person.
- Know how to disconnect electricity to the PDU and data center in case of emergency.
- Wear the right protective equipment.
- Use double-insulated tools.
- Strictly follow local and site regulations.

1.5 Electromagnetic Interference

This is a Class A product. In a domestic environment, the product may cause radio interference in which case the user may be required to take adequate measures.

Chapter 2 : PDU Overview

2.1 Product Introduction

Delta Power Distribution Unit (PDU) distributes power to equipment mounted in racks and enclosures used in data centers, and IT and telecom installations. The PDU installs vertically without tools in the rear of a rack and without requiring a unit space. Input to the PDU can be either single phase or three phase America/ Taiwan or International voltages.

The PDU consists of receptacles distributed vertically, an attached line cord with plug, a display module and an optional SNMP communication module. Connecting by cord to the AC mains or a UPS output, the PDU requires a user-supplied facility receptacle and circuit breaker for input connection and protection.

The output of the PDU supplies single phase, cord connected AC devices via receptacles on the PDU. The output receptacles are divided into 2 or 3 groups. Each receptacle group is protected by a circuit breaker. The optional communication module plugs into the PDU to provide a communications interface with SNMP compatible network management systems, Which lets you remotely monitor the PDU over an Ethernet network.

2.2 Package Contents

The PDU package contains the following items:

No.	Item	Quantity
1	Power Distribution Unit	1
2	Communication Serial Cable (1.8m)	1
3	User Manual	1
4	24 Wire Mounts & Cable Ties for PDU1211B 28 Wire Mounts & Cable Ties for PDU1313B 39 Wire Mounts & Cable Ties for PDU2316B	24/ 28/ 39
5	Mounting Bracket	3

Chapter 3 : PDU Installation

You can install the PDU into a rack using the PDU's attached toolless mounting pegs or using mounting brackets (provided). Once in the rack you can plug power cords into the PDU's sockets and secure them to the PDU's retention slots using the cable ties (provided).

3.1 Toolless Mounting (Delta Standard Rack Cabinet)

You can mount the PDU without tools into a Delta standard rack cabinet. The PDU installs vertically at the rear of the rack in the cable channel directly behind the rear vertical mounting rails.

- 1 Locate the mounting holes in the channel in the rear panel of the rack.
- 2 Hold the PDU vertically and align its toolless mounting pegs to the mounting holes. Note that either end can face top or bottom. See *Figure 1*.

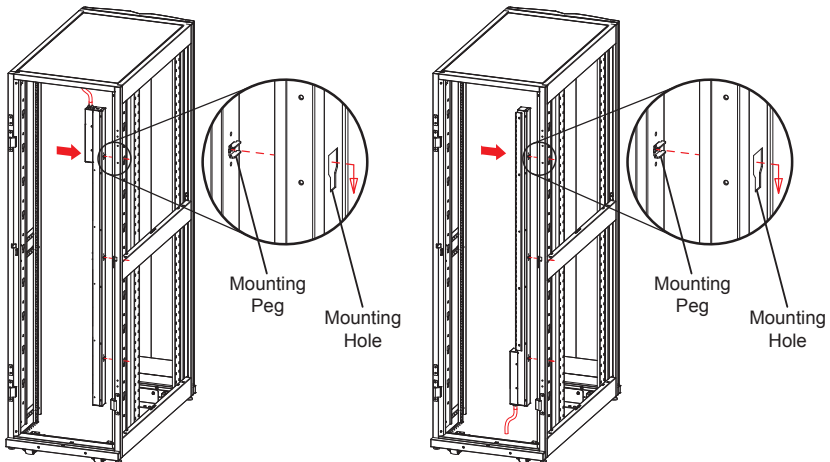

(Figure 1)

- 3 Slide the mounting pegs into the mounting holes.
- 4 Push the PDU downward until it snaps into place.

3.2 Bracket Mounting (For Other Rack Cabinets)

You can also use the mounting brackets (provided) to mount the PDU into any other standard rack cabinet.

- 1 Choose a mounting position for the PDU.
- 2 Please remove the PDU's toolless mounting pegs. See **Figure 2**.
- 3 Attach the mounting brackets to the PDU using the M4*8mm screws that came with the mounting brackets. See **Figure 3**.



NOTE: Use only the screws and nuts supplied with the rack or mounting brackets.

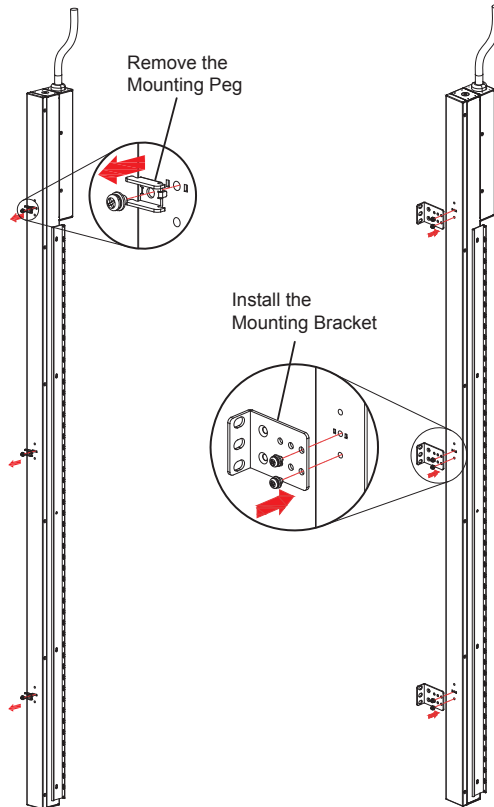

(Figure 2)

(Figure 3)

- 4 Choose a location in the rack for the PDU.
- 5 Install the PDU on a mounting rail in your rack using the M6*12mm screws and M6 cage nuts. See **Figure 4**.

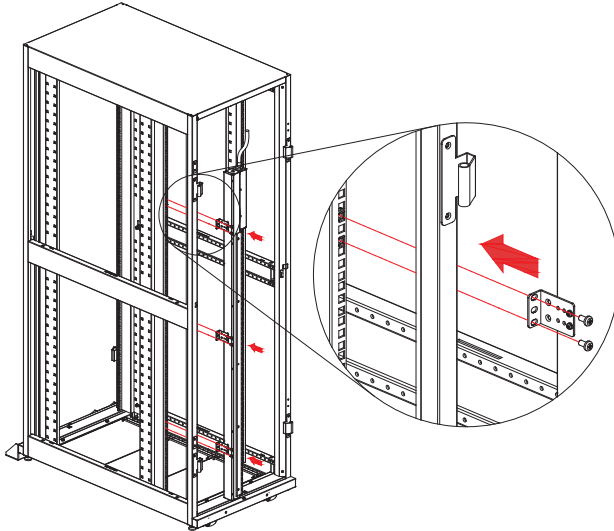

(Figure 4)

Chapter 4 : PDU Connection

4.1 Plug in the PDU

Plug the PDU input power cord into a grounded outlet. Make sure the grounded outlet does not share a circuit with a heavy electrical load such as an air conditioner or refrigerator.

4.2 Attaching Cords

- 1 Plug the power cords into the PDU's sockets (1) and insert the cable ties into the wire mounts (2). Please refer to **Figure 5**.

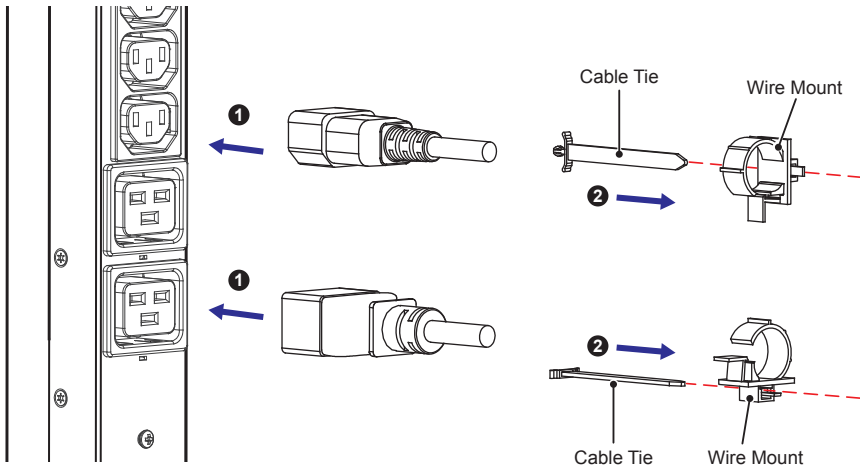

(Figure 5)

- 2) Firmly insert the wire mounts into the power cords (3) and insert each cable tie's peak into the slot (4). Please refer to **Figure 6**.

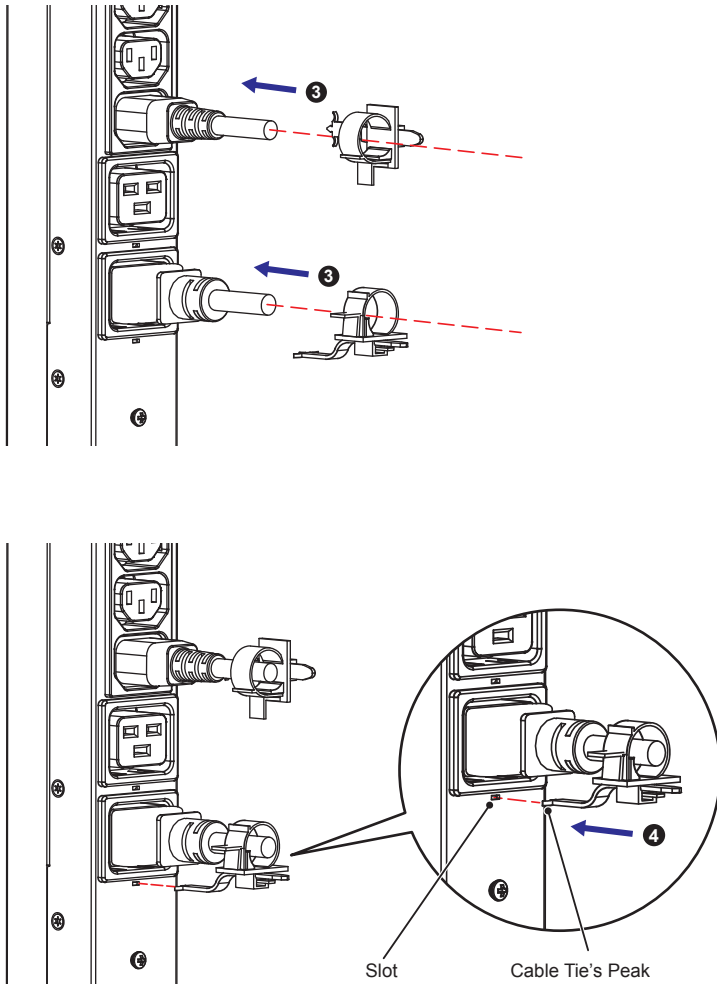

(Figure 6)

3 Turn and clip each wire mount firmly (5). Please refer to **Figure 7**.

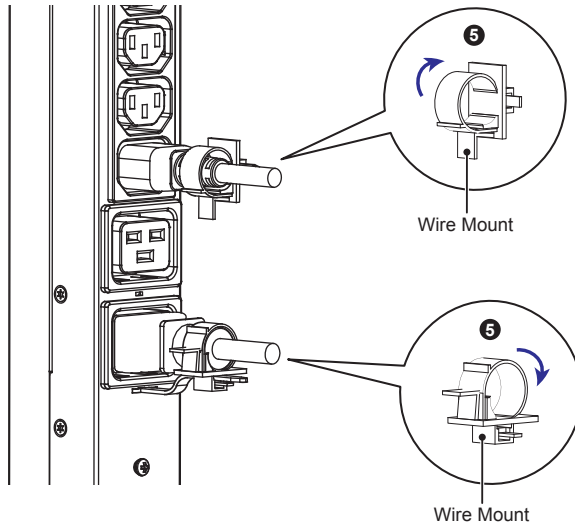

(Figure 7)

Chapter 5 : Display Operation

The PDU front panel has a two-digit LED display that shows the current in each circuit breaker, a scroll button to scroll through values, and alarm LEDs, which indicate current overload and voltage-out-of-range conditions. The following describes the front panel of each PDU model.

5.1 Front Panel Descriptions

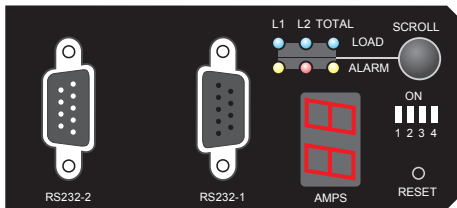

Models

PDU1211B
PDU1313B

LED	Color
L1	Blue
L2	Blue
TOTAL *1	Blue
Alarm 1 *2	Red / Yellow (Bicolor LED)
Alarm 2 *2	Red / Yellow (Bicolor LED)
Alarm 3 *2	Red / Yellow (Bicolor LED)
7 segment display (2x)	Red



NOTE:

*1: TOTAL = L1 + L2 current

*2: Alarm Definitions:

1. Yellow LED: Minor alarm
2. Red LED: Major alarm

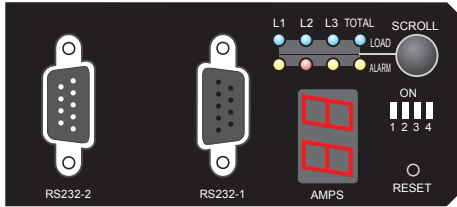

Model
PDU2316B

LED	Color
L1	Blue
L2	Blue
L3	Blue
TOTAL * ¹	Blue
Alarm 1 * ²	Red / Yellow (Bicolor LED)
Alarm 2 * ²	Red / Yellow (Bicolor LED)
Alarm 3 * ²	Red / Yellow (Bicolor LED)
Alarm 4 * ²	Red / Yellow (Bicolor LED)
7 segment display (2x)	Red



NOTE:

*¹: TOTAL = L1 + L2 + L3 current

*²: Alarm Definitions:

1. Yellow LED: Minor alarm
2. Red LED: Major alarm

5.2 Scroll Button

The scroll button lets you scroll through the display for each circuit or invert the display.

5.3 View the Display for Each Circuit

1. Push the scroll button once for less than 3 seconds to switch the display (seven segment and flashing blue circuit indicator LED) from one circuit to the next.
2. The circuits are displayed in the following order as you push the scroll button:

Models PDU1211B and PDU1313B: L1, L2 and TOTAL.

Model PDU2316B: L1, L2, L3 and TOTAL.

5.4 Invert the Numerical Display

If you are mounting the PDU in the rack with the circuit breakers at the top, press and hold the scroll button for over 3 seconds to invert the seven segment display 180 degrees.

5.5 Start-up or Reset

During the power on start-up process or after a reset, all indicators and displays light for a minimum of 2 seconds to verify operation. In the case of bicolor LEDs, the color switches every second during this verification process.

5.6 Normal Conditions

1. AMPS – The dual seven-segment display shows current in the load group selected by the user. The value is displayed without a decimal point, for example, 1 Amp is displayed using only the right hand digit. For current values less than 1, $I < 1$, the value is displayed as “0”.
2. Load LED – Under normal conditions, when there are no alarms, all load LEDs glow blue. The blue LED corresponding to the load group current displayed flashes at a 1Hz rate (0.5 second on and 0.5 second off). If an alarm condition exists, the Load LED for the load group(s) affected is not lit. The Load LED for a load group with no alarm still glows blue.
3. If no alarms are present, the display begins to automatically scroll through the load groups after 5 minutes of inactivity. Inactivity is defined as no user input, such as pushing the scroll button, for 5 minutes. When automatically scrolling each load group, current will be displayed for 3 seconds before switching to the next group. When pushing the scroll button during automatic scrolling, the automatic function terminates until the 5-minute inactive criteria is met again.

5.7 Alarm Conditions

1. If a minor alarm condition exists, the LED corresponding to the load group with the alarm condition glows yellow. The blue Load LED for that load group is off.
2. If a major alarm condition exists, the LED corresponding to the load group with the alarm condition glows red. The blue Load LED for that load group is off.
3. When an alarm condition occurs, the display automatically changes to show the circuit with the alarm condition regardless of the present display setting. The automatic scrolling function is disabled when an alarm condition exists.
4. If an alarm condition is displayed and the user scrolls to display another circuit that does not have an alarm condition present, the circuit without an alarm is displayed for 10 seconds. The display then switches back to the circuit with the alarm condition. If an alarm condition is displayed and the user scrolls to another circuit with an alarm condition, the display remains on the last circuit selected with an alarm until the alarm condition clears or the user scrolls to a different circuit.
5. If multiple circuits have concurrent alarm conditions, the last circuit to activate an alarm will be displayed.
6. If a circuit with an active alarm is selected for display, the LED (yellow or red) flashes at a 1 Hz rate (0.5 second on and 0.5 second off).
7. Minor alarm (Yellow LED) conditions include:
 - a. Caution prior to overload
 - b. Over or under voltage caution
8. Major alarm (Red LED) conditions include:
 - a. Overload warning
 - b. Over or under voltage warning

Chapter 6 : Communications

The PDU's serial communication ports are a standard feature. An optional communication module is available that provides an SNMP interface for a network.

6.1 PDU Data

The following PDU data is available via either communications interface:

















- Current in each circuit breaker (measured)
- Voltage on the load side of each circuit breaker
- Alarm condition present
- Unit information, such as model name, serial number, etc.

6.2 Serial Ports

There are two serial ports on the PDU, Serial 1 and Serial 2. Both serial ports communicate via an RS232 interface.

- Serial 1 (RS232-1) is the main serial port for interface with an outside device such as a PC or notebook.
- Serial 2 (RS232-2) is for connecting to an SNMP network module or for connecting multiple PDUs to allow communication between PDU devices.

For communication with multiple PDUs, you need to set different ID numbers for each PDU via the dip switch located on the front display panel. You can connect a maximum of 16 PDUs for multiple PDU communications. To set ID numbers for PDUs, please refer to the table below.

Dip Switch	ID Number	Dip Switch	ID Number	Dip Switch	ID Number
ON  1 2 3 4	0	ON  1 2 3 4	6	ON  1 2 3 4	12
ON  1 2 3 4	1	ON  1 2 3 4	7	ON  1 2 3 4	13
ON  1 2 3 4	2	ON  1 2 3 4	8	ON  1 2 3 4	14
ON  1 2 3 4	3	ON  1 2 3 4	9	ON  1 2 3 4	15
ON  1 2 3 4	4	ON  1 2 3 4	10		
ON  1 2 3 4	5	ON  1 2 3 4	11		

6.3 Communication SNMP module (Optional)

The optional SNMP network module connects to the PDU through the Serial 2 (RS232-2) port. To order SNMP modules or for more information, please contact your dealer.

Appendix 1 : Specifications

Model	PDU1211B	PDU1313B	PDU2316B
Electrical			
Input Connector	Walther 210306	Hubbell C330P6S Walther 230306	Hubbell C360P6W Walther 261306
Output Connectors	(24) IEC320-C13	(24) IEC320-C13 (4) IEC320-C19	(36) IEC320-C13 (3) IEC320-C19
Input Rated Current	16A	24A	40A
Nominal Input Voltage	200-240VAC (1 Phase)	200-240VAC (1 Phase)	200-240VAC (1 Phase)
Input Frequency	50/60 Hz	50/60 Hz	50/60 Hz
Output Voltage	200-240VAC (1 Phase)	200-240VAC (1 Phase)	200-240VAC (1 Phase)
Physical			
Dimensions (W × H × D)	48 × 1250 × 50/90mm	48 × 1250 × 50/90mm	48 × 1560 × 50/90mm
Unit Weight	4.6kg	5.12kg	7.94kg
Environmental			
Temperature	Operating: 0°C to 45°C Storage: -20°C to 65°C		
Altitude	Operating: 0 to 6,600 feet (0 to 2000 meters) Non-operating: 0 to 49,000 feet (0 to 15,000 meters)		
Humidity	Operating: 5 to 95% relative humidity (non-condensing) Non-operating: 5 to 95% relative humidity (non-condensing)		

**NOTE :**

1. Refer to the rating label for the safety rating.
2. All specifications are subject to change without prior notice.

Appendix 2 : Warranty

Seller warrants this product, if used in accordance with all applicable instructions, to be free from original defects in material and workmanship within the warranty period. If the product has any failure problem within the warranty period, Seller will repair or replace the product at its sole discretion according to the failure situation.

This warranty does not apply to normal wear or to damage resulting from improper installation, operation, usage, maintenance or irresistible force (i.e. war, fire, natural disaster, etc.), and this warranty also expressly excludes all incidental and consequential damages.

Maintenance service for a fee is provided for any damage out of the warranty period. If any maintenance is required, please directly contact the supplier or Seller.



WARNING:

The individual user should take care to determine prior to use whether the environment and the load characteristic are suitable, adequate or safe for the installation and the usage of this product. The User Manual must be carefully followed. Seller makes no representation or warranty as to the suitability or fitness of this product for any specific application.

No. 501325330000

Version : V 0.0

Release Date : 2017_09_21

